

# AMP2-16V

## 16-Channel Audio/Video Processing Monitor



Modular 16-channel audio/video workstation with a complete suite of tools for analyzing and managing audio quality, level and loudness, metadata, and more

The leading choice of broadcasters worldwide, Wohler's AMP2-16V could be the last audio monitor you will ever need. The open architecture design, superb quality, upgradeability and ease-of-use is why broadcasters consistently choose the AMP2-16V for their most demanding applications.

Since we invented the in-rack audio monitor, we have not stopped improving it—and the world's best selling and most powerful monitor now offers an even broader set of critical audio management tools. Monitor and analyze all of your audio and video feeds from one compact, convenient and easy to use workstation.

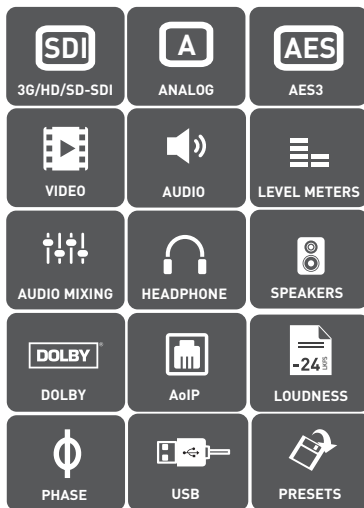

### Features/Benefits

- Monitor, mix, and route embedded AoIP, SDI, AES, analog, and TOSLINK audio sources
- 16-channels of simultaneous, multi-format audio monitoring, metering and management
- Upgradable architecture gives you what you need now and what you may need later
- AoIP options. Mix, level adjust and monitor AES67, Dante or AVB streams. Channels can be re-embedded into an SDI stream, AES, and analog outputs
- Dual high resolution LCD screens with auto-detecting 3G/HD/SD-SDI video
- Display application specific audio, video, or metadata information on either screen
- Loudness monitoring with alarms
- Fully customizable level meters including scale, color, range, thresholds and more
- 32 presets allow complete reconfiguration of the entire unit with one button press
- 16 Hot Keys enable one touch access to solos, mutes, channel trims, presets, or Dolby
- Zooms at the touch of a single button
- "SuperPair" feature offers additional channel pair (17, 18) monitor two intercom or auxiliary device channels
- Menu lockout function prevents unwanted system changes
- Save and copy system presets to other units via Ethernet or Serial connection to PC
- Redundant power supplies for secure transmission chain operation (optional)

### Part Numbers:

Base Units:

AMP2-16V-M: 8130-0200  
AMP2-E16V-M: 8130-0300 (with Dolby E/D/DD+)

Processing Options:

Dante™ AoIP Input 829090	Dante™ Input module with RJ-45 connector.
Ravenna AoIP Input 829091	Ravenna Input module with RJ-45 connector.
3G/HD/SD-SDI 829024	16 Channel 3G/HD/SD-SDI Dual Input Audio/Video Module.
AES Input	829001 8 pair (16-channel) AES Audio Input Module.
AES Output 829002	8 pair (16-channel) AES Audio Output Module.
Analog w/TOSLINK 829021	8 Channel Analog Inputs On DB-25; 8 Channel Analog Outputs On DB-25. Also Includes Optical TOSLINK Input.
Dolby D/E/DD+ 829014	Add support for monitoring Dolby® D/E/DD+ (AMP2-16V-M only).

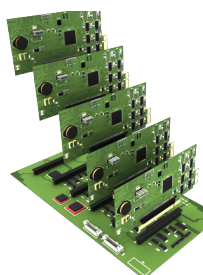

# AMP2-16V

## Multi-Channel Audio Monitoring & Metering

### Block Diagram

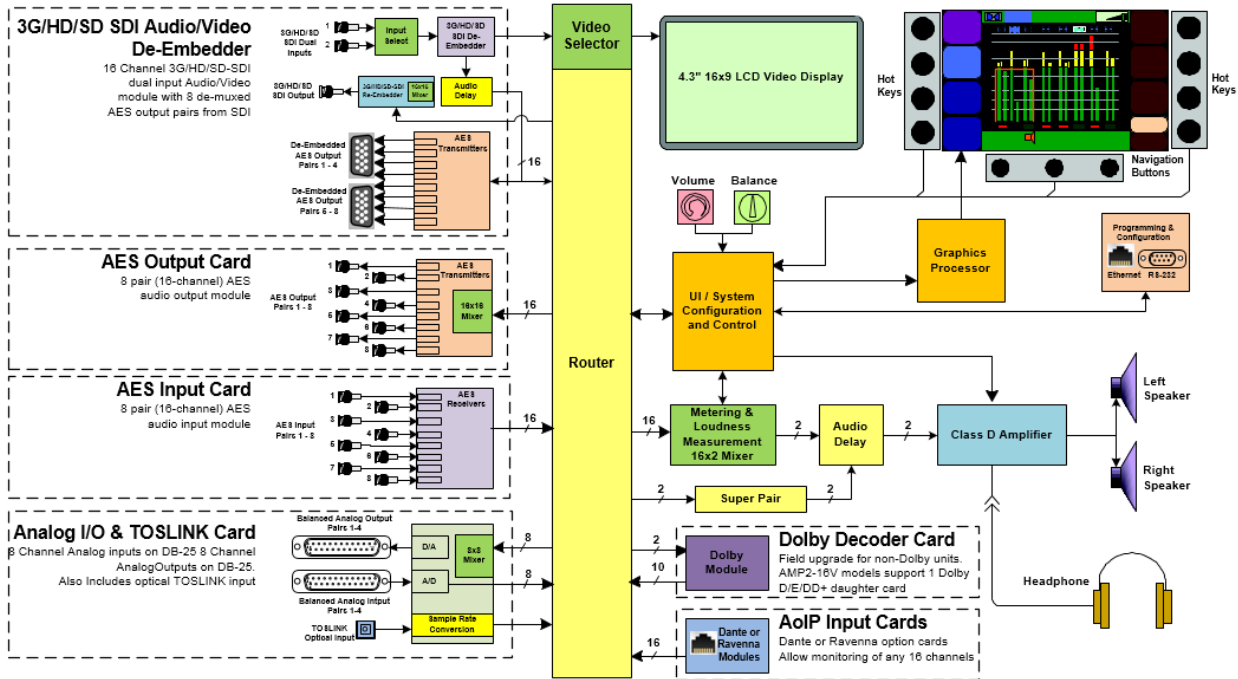

### Specifications

Dimensions (W x H x D)	19" x 3.5" x 15" (483 mm x 89 mm x 381 mm)
Shipping Weight / Net Weight	23 lbs. (10.4 kg) / 18 lbs. (8.16 kg)
Level Meter Resolution	310 segments
Level Meter Scaling	AES • VU • Ext. VU • BBC • EBU • Nordic • DIN • Custom
Level Meter Parameters	Range Threshold Reference Segment Colors Ballistic Pairwise Phase Indicators Limits Lower Scale Compression Arbitrary Phase Indicators
Loudspeaker Power	15 W per speaker
Acoustic Frequency Response	± 5 dB between 60 Hz and 16 kHz (-10 dB at 50 Hz, 20 kHz)
AES and SDI Input Termination	75 Ω Unbalanced
Analog Input Impedance	40k Ω
Noise	Better than -75 dB below full output
THD	<0.15% at any level below limit threshold
Power Requirements	100 V to 240 V AC ± 10%, 50/60 Hz
Power Consumption	150W maximum