



CONFIDENCE IS EVERYTHING.™

World Leader of In-Rack, Audio, Video, Data Monitoring, and Closed Captioning Solutions

AMPx SDA Series

- AMP1-SDA
- AMP2-SDA

Digital Audio Speaker Monitors

User Guide

Part Number 821027, Revision C

© 2010 Wohler Technologies, Inc. and PANORAMA. All rights reserved.

This publication is protected by federal copyright law. No part of this publication may be copied or distributed, stored in a retrieval system, or translated into any human or computer language in any form or by any means electronic, mechanical, manual, magnetic, or otherwise, or disclosed to third parties without the express written permission of Wohler Technologies.

Reproduction

Licensed users and authorized distributors of Wohler Technologies, Inc. products may copy this document for use with Wohler Technologies, Inc. products provided that the copyright notice above is included in all reproductions.

Customer Support

Wohler Technologies, Inc.
31055 Huntwood Avenue
Hayward, CA 94544
www.wohler.com

Phone: 510-870-0810
FAX: 510-870-0811
US Toll Free: 1-888-596-4537
(1-888-5-WOHLER)
Web: www.wohler.com
Sales: sales@wohler.com
Support: support@wohler.com

Disclaimers

Even though Wohler Technologies, Inc. has tested its equipment and software, and reviewed the documentation, Wohler Technologies, Inc. makes no warranty or representation, either express or implied, with respect to software, documentation, their quality, performance, merchantability, or fitness for a particular purpose.

Wohler Technologies, Inc. reserves the right to change or improve our products at any time and without notice.

In no event will Wohler Technologies, Inc. be liable for direct, indirect, special, incidental, or consequential damages resulting from any defect in the hardware, software, or its documentation, even if advised of the possibility of such damages.

Some states do not allow the exclusion or limitation for incidental or consequential damages, so the above exclusion or limitation may not apply to you.

Printing

This document is intended to be printed on a duplex printer, such that the copy appears on both sides of each page. This ensures that all new chapters start on a right-facing page.

This document looks best when printed on a color printer since some images may be indistinct when printed on a black and white printer.

Other Technologies and Products

Dolby, Dolby Digital, Dolby D, and Dolby E are registered trademark of Dolby Laboratories, Inc.

Microsoft Windows, and Internet Explorer are registered trademarks of Microsoft Corporation.

Last Update

March 23, 2010

AMPx-SDA User Guide

Introduction

Overview

The AMPx-SDA Series of audio monitors provides self-powered, full-fidelity stereo monitoring in the smallest rack space possible. All models in the series contain four high performance transducers driven by three power amplifiers: two amplifier/driver combinations handle midrange and high frequency information in stereo, while the third center channel reproduces information below the 500 Hz crossover point.

Topics

Topics	Page
Introduction	1
Safety Instructions	2
Installation Recommendations	3
Features	4
Applications	5
Specifications	6
Front Panel Controls	8
Rear Panel Connectors	11
Technical Functional Overview	16

Safety Instructions

1. Read, keep, and follow all of these instructions; heed all warnings.
2. Do not use this equipment near water or moisture.
3. Use only a dry cloth to clean the equipment.
4. Do not block any ventilation openings. Install only in accordance with the instructions in the section entitled, "[Installation Recommendations](#)" on [page 3](#).
5. Do not install near any heat source such as a radiator, heat register, amplifier, or stove.
6. Do not attempt to plug the unit into a two-blade outlet (with only two prongs of equal width).

IMPORTANT: By design, these monitors will only plug into a three-prong outlet for your safety. If the plug does not fit into your outlet, contact an electrician to replace the obsolete outlet.

7. Protect the power cord from being walked on or pinched, particularly at plug's source on the equipment and at the socket.
8. Use only the attachments/accessories specified by the manufacturer.
9. Unplug the equipment during lightning storms or when unused for long periods of time.
10. Refer all servicing to qualified service personnel. Servicing will be required under all of the following conditions:
 - The equipment has been damaged in any way, such as when the power-supply cord or plug is damaged.
 - Liquid had been spilled or objects have fallen onto the equipment.
 - The equipment has been exposed to rain or moisture.
 - The equipment does not operate normally.
 - The equipment has been dropped.

Installation Recommendations

Mounting

Note: If you wish to set the AES Input Termination, AES Status Error Type, AES Input Level Gain, Line Level Calibration, Meter Gain Calibration, and/or Bargraph Display Mode via the DIP switches (accessed on the rear panel) be sure to do so BEFORE installing the unit into an enclosed rack or console. See pages 12 and 14 for setting information.

The unit should be mounted where convenient for operating persons, ideally at approximately ear level for best high frequency response. Its superior magnetic shielding eliminates concerns about locating it adjacent to most types of CRT monitors, including even high-resolution color monitors.

Heat Dissipation

Heat dissipated by the speaker amps is conducted directly to the left side of the chassis; no special considerations for cooling are necessary as long as the ambient temperature inside the rack area does not exceed approximately 40°C (104°F).

Sympathetic Vibration

Sympathetic vibration from other equipment (cables, etc.) in the rack may be serious enough to interfere with the unit's sound quality out in the listening area. The use of thin card stock and/or felt or foam weather-stripping type materials between adjacent vibrating surfaces, or tying up loose cables, etc., may be required to stop vibrations external to the unit.

Mechanical Bracing

Even though the unit is fairly heavy, the chassis is securely attached to the front panel at eight points along its surface, not just at the four corners of the chassis ears. This feature will reduce or eliminate rear bracing requirements in many mobile/portable applications. The weight of internal components is distributed fairly evenly around the unit.

Audio Connections

Connection of the audio feeds is straightforward. For digital inputs, Impedances are $75\ \Omega$ for the unbalanced BNC connectors and $110\ \Omega$ for the balanced XLR connectors. Analog inputs have an impedance of $40k\ \Omega$ for the balanced XLR connectors. Care should be exercised to avoid mismatched cable types and other similar causes of undesired reflections in RF signal systems.

Electrical Interference

As with any audio equipment, maximum immunity from electrical interference requires the use of shielded cable; however, satisfactory results can sometimes be obtained without it. The internal circuitry common is connected to the chassis.

AC Power

The unit's AC mains connection is via a standard IEC inlet, with safety ground connected directly to the unit's chassis. The universal AC input (100-240VAC, 50/60Hz) switching power supply is a self-resetting sealed type, with automatic over-voltage and over-current shutdown. There is no user-replaceable fuse in either the primary or secondary circuit.

Features

- Excellent high frequency response for positive detection of background whine and noise
- Audible and visual indication of phase/polarity problems
- Thorough magnetic shielding for placement next to video monitors
- Two high-resolution 26-segment tri-color LED bar graph level meters
- SDI input and loop-through on unbalanced BNC connectors

- AES/EBU input on unbalanced BNC connector
- Analog stereo inputs on two balanced XLR connectors
- AES output (converted from SDI input) on BNC connector
- Analog output of selected input on two balanced XLR connectors
- SDI signal status indication LED
- AES signal status indication LED
- SDI subgroup 1 or 2 (of Group #1) source selection via front panel toggle switch
- SDI/AES source selection via front panel toggle switch
- Digital/analog source selection via front panel toggle switch
- Headphone output
- Power indication LED

Applications

The AMP1 Digital series is ideally suited for use in VTR bays, mobile production vehicles, teleconferencing installations, multimedia systems, satellite links and cable TV facilities, and on-air radio studios. Designed and manufactured in the U.S., the AMP1-SDA is backed by a strong warranty and a satisfaction guaranteed return policy.

Specifications

Table 1–1 Audio Specifications for the AMPx-SDA Series Monitors

Specifications	AMP1-SDA	AMP2-SDA
Input connectors	Analog IN: XLR (3-pin female) 2 each SDI IN: BNC (female) 1 each AES IN: BNC (female) 1 each	
Digital input impedance	XLR: 110 Ω (Balanced) BNC: 75 Ω (Unbalanced)	
Analog input impedance	XLR: 40k Ω (Balanced)	
Input Level for Maximum Output (Volume Full On)	0 dBv balanced	
Input Overload	+26 dBv balanced	
Peak Acoustic Output (@ 2 ft.)	98 dB SPL	104 dB SPL
Response, Sixth Octave:	80 Hz - 16 kHz \pm 7 dB) (-10 dB @ 50 Hz, 22 kHz)	80 Hz - 16 kHz \pm 5 dB) (-10 dB @ 40 Hz, 20 kHz)
Power Output		
RMS Each Side (4 Ω)	10 W transient / 5 W continuous	14 W transient / 10 W continuous
RMS Bass (4 Ω)	20 W transient / 10 W continuous	35 W transient / 25 W continuous
Distortion, Electrical:	< 0.15% at any level below limit threshold	
Distortion, Acoustic:	8% or less at worst case frequencies above 180 Hz including cabinet resonance; typically less than 2%	6% or less at worst case frequencies above 120 Hz, including cabinet resonance; typically less than 1.5%
Hum and Noise	better than -68 dD below full output	
Magnetic Shielding:	< 1 Gauss any adjacent surface	<0.8 Gauss any adjacent surface
Power Consumption (Average Maximum):	35 W	45 W
AC Mains input:	100-240VAC, 50-60 Hz	

Table 1–2 Physical Specifications for the AMPx-SDA Series Monitors

Specifications	AMP1-SDA	AMP2-SDA
Dimensions (H x W x D)	1.75 x 19 x 12 inches 44 x 483 x 305 mm	3.5 x 19 x 12 inches (89 x 483 x 305 mm)
Weight	14 lbs. (6.4 kg)	18 lbs. (8.2 kg)

Table 1–3 Digital to Analog Specifications for the AMPx-SDA Series Monitors

Specifications	AMP1-SDA	AMP2-SDA
D to A gain calibration, (dBu = dBFS):	+8 = -20, +4 = -20, +6 = -9, 0 = -18 (switch selectable)	
AES sampling rate:	32 to 48 kHz, auto-select	
D to A converter:	24-bit low jitter	
Converted analog out (S/N):	>90 dB	
Converted analog out (THD):	< 0.008%	
AES Termination:	75Ω removable, unbalanced	

Table 1–4 Meter Specifications for the AMPx-SDA Series Monitors

Specifications	AMP1-SDA	AMP2-SDA
Level Meter Type:	26-segment tri-color LED bargraph display	53-Segment LED bargraph
Level Calibration	0, +4, +6, +8 dBv	
Frequency Response	20 Hz to 20 kHz (±0.5 dB)	
LED Segment Colors	Tricolor (red, amber, green)	
Metering Range:	65 dB	
Display Modes:	VU with PPM or Peak Hold (Select)	
VU Characteristics, Rise Time:	300 ms to 99% of full indication	
Decay Time:	300 ms	
PPM Characteristics, Attack Time:	10 ms	
Decay Time:	2 seconds, 0 to -20 dB	
Meter dynamics:	VU (bar) and/or PPM (dot), select	

Table 1–4 Meter Specifications for the AMPx-SDA Series Monitors

Specifications	AMP1-SDA	AMP2-SDA
Dynamics modes:	PPM: 20 dB decay in 1.5 sec. or 3 sec hold VU: 3 sec. hold or 10 sec. hold	
Midscale resolution:	1 dB	2 dB
Scale	+16 to -50 dB	
Segment size:	.158" x .04" (4.0132 x 1.016 mm)	

Front Panel Controls

Figure 1–1 AMP1-SDA Front Panel

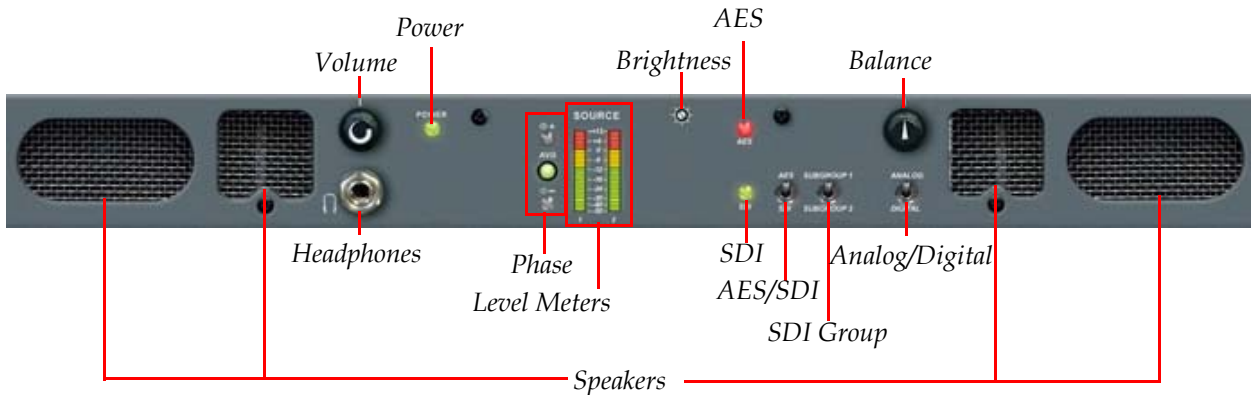

Figure 1–2 AMP2-SDA Front Panel



- **Speakers:** The internal speaker system is comprised of two mid-range tweeter speakers (left and right) and woofer speakers. The AMP1-SDA has two woofers wired in series and the AMP2-SDA has one larger woofer. The two side channel speakers reproduce, in stereo, only the mid and high frequencies. Please note that the woofer speaker (center) is not a dedicated center nor LFE speaker.
- **Power Indication LED:** This LED glows green to indicate the AMPx-SDA is connected to mains power and an operation voltage is present.
- **Audio Level Meter LED Bar Graphs:** Audio levels for the selected source (right and left) are visually displayed via these two high-resolution, tricolor LED bargraph meters. Dynamic range for these meters is 65 dB and they are able to simultaneously display signal levels using both PPM and VU standards. Alternate display modes are user selectable via a DIP switch accessible through the top cover of the unit. Contact the factory for additional information concerning meter scales and ballistics.
- **Volume:** This controls the loudness of the audio reproduced by the internal speakers or connected headphone. Clock-wise rotation of this control increases the loudness of the monitored audio.
- **Headphones:** Select the headphone audio sources as you would for the internal speakers. When you plug in headphones, the internal or external speakers will mute. This jack accepts a standard 1/4" phone type stereo plug.
- **Analog/Digital Source Select:** This two position toggle switch allows the operator to choose between two primary input sources; **Analog** or **Digital**. When this toggle switch is set to **Analog**, the unit will monitor the signals as input on the two rear panel **Analog In** XLR connectors. When this toggle switch is set to **Digital**, the unit will monitor one of two types of digital signal sources as chosen by the **Digital Source Select** switch.
- **Bar Graph Brightness:** This control is recessed into the front panel and can be accessed using a small screwdriver. Turning it clockwise will increase the relative brightness of the bargraph display LED segments. Adjusting this one control will simultaneously affect the brightness of both bargraph displays on the front panel.
- **Phase Indication LEDs:** These three LEDs offer instant verification of phase (polarity) conditions in the pair of channels selected for monitoring in the left/right channel speakers. There are three LEDs; the

two smaller LEDs labeled **Fast** (left side of the **Phase** section) show instantaneous phase relationships in the signal, while the larger LED, labeled **Avg** (right side of the **Phase** section), will indicate the *average* phase condition. The small **Fast** LED on the left glows (or blinks) green when signals are *in-phase*. The small **Fast** LED on the right glows (or blinks) amber for *out-of-phase* signals. The larger **Avg** LED indicates the *average* phase condition by glowing green for *in-phase* conditions, or red for *out-of-phase* conditions. In general, it is sufficient to regard the **Avg** LED (average phase condition) as adequate for proper phase monitoring. While it is normal for stereo signals to contain some intermittent instantaneous out-of phase and in-phase conditions (small LEDs), a steady red glow of the larger LED almost always indicates an out-of-phase alarm condition.

- **Balance:** This pans the volume balance between the left and right speakers. If the balance is adjusted hard left or hard right, a slight left/right channel mix is retained (only in low bass frequencies) so that phase discrepancies can be discerned.
- **SDI Subgroup Select (1 or 2):** This 2-position toggle switch allows the operator to choose whether the unit will monitor sub-group 1 or sub-group 2 of the SDI data stream when the **Digital Source Select** switch is set to **SDI**. Subgroup selections 1 and 2 are derived from Group 1 as follows:
 - Subgroup 1 = Channels 1 and 2
 - Subgroup 2 = Channels 3 and 4
- **Digital Signal Error LEDs:** These two bi-color (Green/Red) LEDs indicate the input presence and status of the two types of digital signals; AES and SDI. These LEDs function whether or not either of the digital signals is selected for monitoring through the unit.
 - **AES Signal Error LED:** This LED, labeled **AES**, glows green as long as a valid AES/EBU digital datastream is being received. It glows red to indicate errors. By setting a rear panel DIP switch, two types of error detection are available:
 - 1) Reception errors: errors in reception of data or no data stream at all, or
 - 2) Reception and data errors: errors in reception and data errors identified by the sending device (possibly invalid).

- **SDI Signal Error LED:** This LED, labeled **SDI** glows green as long as a valid SDI digital datastream is being received. It glows red if TSR errors are present in the signal. If there is no SDI signal present the LED will be unlit.

Rear Panel Connectors

Common Connectors

- **Power:** Attach a standard IEC-320 power cord between this connector and mains power (100 - 250VAC, 50/60 Hz). The front panel **Power LED** will glow green to indicate operating voltages are present.
- **AES Out (From SDI):** The **AES/EBU Out** outputs an AES/EBU signal as converted from the SDI input and as selected by the **SDI Group Select** switch. This connector is configured for an unbalanced, 75 W connection.
- **AES Termination and Error Type DIP Switch:** This 4-position DIP switch is used to set the termination characteristics for the AES inputs and select the AES signal error indication type.
 - **AES Input Termination:** In the event that the AES input channel is fed to downstream equipment (via a "Y" or "T" connector), then DIP switch Section S2 must be placed in the unterminated (up) position. If there is no downstream equipment connected, then Section S2 must be placed in the terminated (down) position. See [Figure 1-3](#) below termination settings.

Figure 1-3 AES Termination Settings

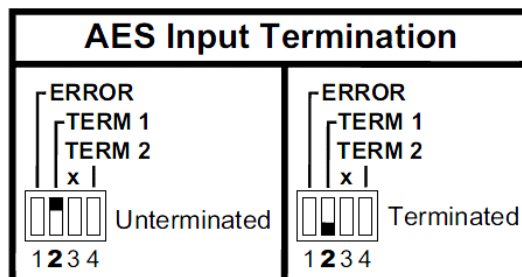

Note Position 3 is not used.



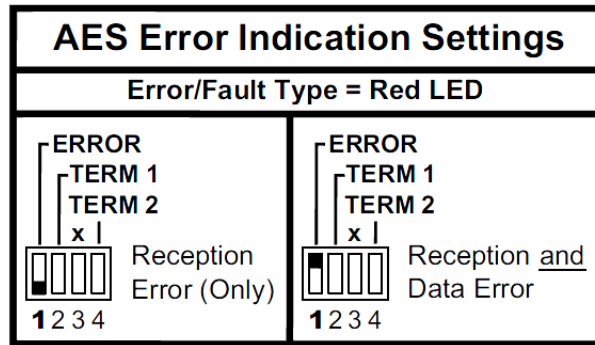

- **AES Error Indication Type:** There are two DIP switch selectable modes of AES error detection that will create a RED error indication in the AES Signal Error Indication LED on the front panel;
 - 1) Reception errors: errors in reception of data or no data stream at all (S1=Down), or
 - 2) Reception and data errors: errors in reception and data errors identified by the sending device (possibly invalid) (S1= Up). See [Figure 1-4](#) for AES error DIP switch settings.

Figure 1-4 AES Error Indication Settings



- **AES Input Connector:** The **AES/EBU IN** input connector is meant to receive standard AES/EBU signals. This female BNC connector is configured for an unbalanced, 75 Ω connection. Note that the unit will monitor the **AES/EBU In** input *only* when the **Analog/Digital Source Select** switch is set to **Digital** *and* the **Digital Source Select** switch is set to **AES**.
- **AES Input Level Gain Calibration DIP Switch:** Input Level Gain Calibration, the analog level which corresponds to a given digital input value, is settable via this DIP switch. The factory setting is +4 dB (analog) = -20 dBFS (digital). See the silk-screened chart on the rear panel or the diagram below for gain calibration settings.

Figure 1–5 AES DA Conversion Gain Calibration Settings

AES D/A Conversion Gain Calibration Settings	
	0 dB = -18 dBFS
	+4 dB = -20 dBFS
	+6 dB = -9 dBFS
	+8 dB = -20 dBFS
12	

- SDI In and Out:** The **SDI In** female BNC connector is meant to receive standard SDI signals. The **SDI Out** female BNC connector outputs a reclocked (regenerated) copy of the signal entering the **SDI In** input connector. Both connectors are configured for unbalanced, 75 Ω connections. Note that the unit will monitor the SDI input only when the **Analog/Digital Source Select** switch is set to **Digital** and the **Digital Source Select** switch is set to **SDI**.
- Selected Analog Out (from Digital Source):** These two 3-pin male XLR connectors are analog outputs of the selected digital source as selected for the left and right speakers and level meters. The left connector outputs the left channel (or Channel A) and the right outputs the right channel (or Channel B). Both connectors are configured for low impedance connections and the output signals are not affected by the **Volume/Balance** controls or headphone mute. For XLR pinout information see [Figure 1–6](#) below.

Figure 1–6 XLR Pin-Outs

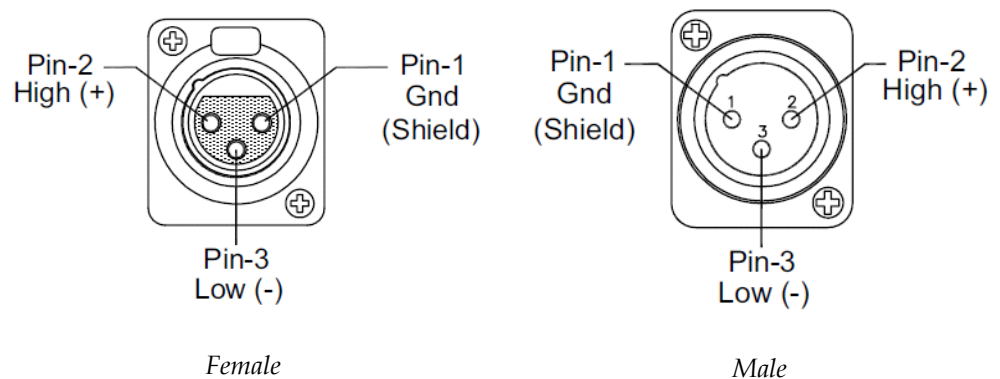

- **Analog In:** These two 3-pin female XLR connectors accept standard analog audio signals. Both connectors are configured for balanced 40k Ω connections. Note that the unit will monitor analog signals input on these two connectors only when the **Analog/Digital Source Select** switch on the front panel is set to **Analog**. For XLR pinout information see the [Figure 1-6 on page 13](#).

AMP1-SDA-Specific Connectors

Figure 1-7 AMP1-SDA Rear Panel

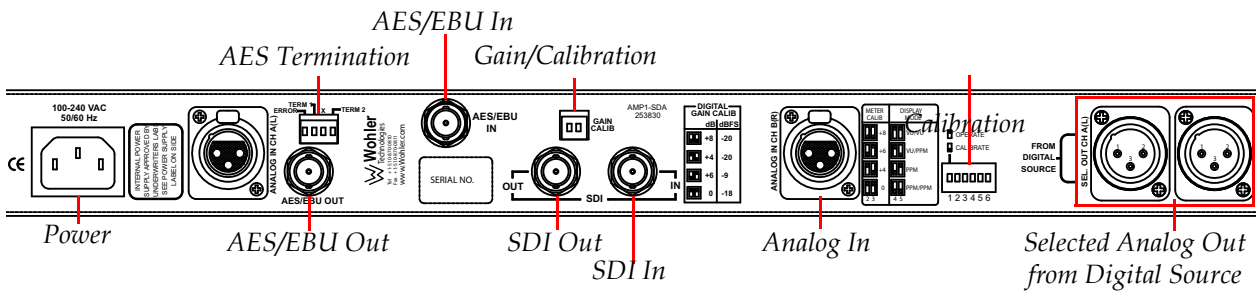

- **Level/Gain Calibration and Display Mode - 6-Position DIP Switch:** This DIP switch sets the Line Level Calibration, Meter Gain Calibration, and Bar Graph Display Mode.

Figure 1-8 Rear Panel DIP Switch Settings

AMP1 Digital LM26 Rear Panel DIP Switch Settings		
Line Level Calibration	Meter Gain Calibration	Display Mode "Floating" Segment
<p>1 x</p> <p>Calibrate</p> <p>Operate</p> <p>1 2 3 4 5 6</p>	<p>2 3 x</p> <p>+8 dB</p> <p>+6 dB</p> <p>+4 dB</p> <p>0 dB</p> <p>1 2 3 4 5 6</p>	<p>4 5 x</p> <p>VU Peak - 10 Second Hold</p> <p>VU Peak - 3 Second Hold</p> <p>PPM Peak - No Hold</p> <p>PPM Peak - 3 Second Hold</p> <p>1 2 3 4 5 6</p>

Note: Position-6 of DIP switch is not functional

- **Line Level Calibration:** The unit is calibrated at the factory. To recalibrate:
 - 1) Turn on the power.
 - 2) Apply a reference level (nominal 0) signal to all four channels.
 - 3) Make sure the Gain Calibration DIP sections (S2, S3) are set to the nearest level (i.e., 0, +4, +6 or +8).
 - 4) Place section S1 of the DIP switch in the DOWN position.
 - 5) Wait 10 seconds. The unit will remove the previous calibration. The unit will make sure that all four channels are within ± 4 dB of nominal zero. If all four channels are within this range then the new calibration will be applied. If any channel is outside this range then no new calibration will be applied.
 - 6) Place section S1 of the DIP switch in the UP position and return unit to service. If you want to calibrate again, turn off the power to the unit and repeat steps 1 through 6. See [Figure 1-8 on page 14](#) for settings.
- **Meter Gain Calibration:** DIP switch sections S2 and S3 determine the Gain Calibration, which adjusts the level of the input signal and the resultant "0" level displayed on the LED bargraphs. Factory setting is +4 dB. See [Figure 1-8 on page 14](#) for all settings.
- **Bar Graph Display Mode:** DIP switch sections S4 and S5 determine how peak levels are displayed for the four associated meters on the front panel. S4 selects either the PPM level or a new auto-reset Peak Hold of the VU level (not the PPM value). When S3 is set for VU Peak, S5 sets the Hold time to either 3 or 10 seconds. If S4 is set for PPM Peak, S5 determines whether it is displayed in the original floating PPM dot mode (no hold, continuous decay of 20 dB in 1.5 seconds) or as a 3 second auto-reset hold. The factory default setting is PPM Peak - No Hold (continuous decay of 20 dB in 1.5 seconds). See [Figure 1-8 on page 14](#) for all settings. Note that section S6 on the DIP switch is not used.

AMP2-SDA-Specific Connectors

Figure 1–9 AMP2-SDA Rear Panel

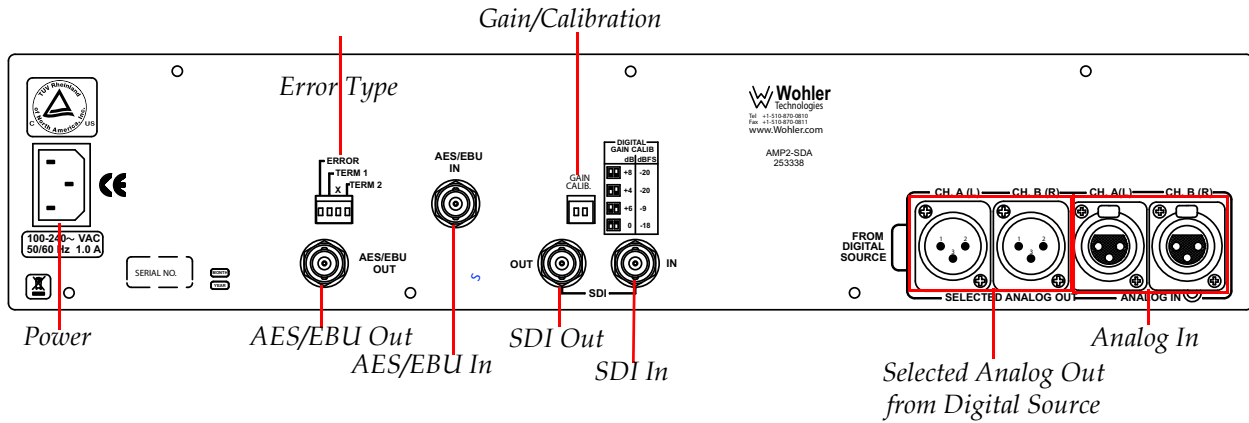

Technical Functional Overview

Figure 1-10 below illustrates the overall functionality of the AMPx-SDA Series monitors.

Figure 1–10 AMPx-SDA Block Diagram

