



General Description

The Rane AD 22S is a fully balanced two-input, two-output Audio Delay unit designed for multiple applications, including speaker array synchronization and precision audio-to-video alignment. With two distinct modes, the AD 22S offers the functionality of dedicated devices within a single rack unit. Featuring a range of 2.00 to 999.99 ms, this unit provides delay displayed in units of time, distance, or frames. Use the dedicated Video mode to provide almost a full second of audio delay in 0.5 frame increments for all standard NTSC or PAL/SECAM frame rates.

The AD 22S can operate as two independent channels or as a linked or stereo pair. Front panel controls let you choose settings for each channel that can be stored into two nonvolatile memory

locations for quick and easy access at any time. Bypass relays for each channel automatically connect should the device lose power. Your settings are always saved into working memory and restored upon power up. Rear terminals let you connect standard switches to recall settings remotely.

The AD 22S's balanced XLR inputs and outputs offer the Rane standard of audio quality, with 24-bit processing and delay precision down to 0.01 ms. With the ability to provide unity gain up to a maximum input level of 24 dBu, the unit can be used with standard high-impedance devices or in a mixed environment using 600 Ω equipment. LEDs on the front panel indicate signal presence and alert when the signal is nearing the maximum input level.

Features

Two distinct modes of operation: Distance & Video

Distance Mode

- Display in milliseconds, feet, or meters
- 2.00 to 999.99 ms Delay Range per channel
- 0.01 ms resolution
- Large backlit LCD display
- Two nonvolatile memories per channel for each alignment mode
- Remote memory recall port on rear
- Front panel lockout port on rear
- Failsafe bypass relay for each channel
- Internal universal power supply (100-240 VAC)

Video Mode

- Display in frames per second or milliseconds
- Compatible with NTSC and PAL / SECAM frame rates
- 0.5 frame resolution

Features and Specifications

Parameter	Specification	Limit	Units	Conditions/Comments
Delay Range	2.00 to 999.99	1%	ms	
Distance Increment	0.01 and 1.00		ms	Each channel independent
Video Increment	0.5		frames	Each channel independent
.....NTSC (North America, Philippines, Japan)	23.976, 24, 29.97, 59.94, 60		fps	
.....PAL / SECAM (Europe, Australia, China, Brazil)	25.00 , 50		fps	
Sampling Frequency	50,000		Hz	
Data Conversion	24		bit	
Audio Connectors	XLR			Pin 2 (+)
Inputs: Type	Active balanced			
.....Impedance	20 k	1%	Ω	Balanced, line to line
.....Max Level	24	±0.5	dBu	
Outputs: Type	Active balanced			
.....Impedance	50	±10	Ω	Balanced, line to line
.....Max Level	24	+0/-0.6	dBu	
Output Relays	Yes			Auto-bypass on power loss
LED Thresholds: Clip	3 before converter overload	1	dB	+22 dBu @ 1 kHz
.....Signal Present	-47 below Clip LED	1	dB	-25 dBu @ 1 kHz
Frequency Response	20 Hz - 22 kHz	+0/-3	dB	+4 dBu, 20 Hz to 20 kHz
System Gain: High-Impedance Load	0	±0.5	dB	Load = 10.0 kΩ balanced, +4 dBu, 20 Hz to 22 kHz
..... 600 Ω Load	0	+0/-1	dB	Load = 600 Ω balanced, +4 dBu, 20 Hz to 22 kHz
THD + Noise	0.006	±0.002	%	+4 dBu, 20 Hz to 20 kHz, 30 kHz BW
Signal-to-Noise Ratio	86	±2	dB	+4 dBu, 20 Hz to 20 kHz
Dynamic Range	108	±1	dB	+24 dBu, 20 Hz to 20 kHz, A-weighted
Crosstalk	-90		dB	+4 dBu, 20 Hz to 20 kHz
Propagation Delay	2.00	1%	msec	Bypass off
Power Supply Requirement	100 to 240 VAC, 50/60 Hz			7 W
Agency Listing	UL/cUL/CE			
Unit: Construction	All Steel			
.....Size	1.75"H x 19"W x 5.25"D (1U)			(4.4 cm x 48.3 cm x 13.3 cm)
.....Weight	4 lb			(1.8 kg)
Shipping: Size	4.25" x 20.3" x 13.75"			(11 cm x 52 cm x 35 cm)
.....Weight	10 lb			(4.5 kg)
<i>Note: 0 dBu = 0.775 Vrms</i>				

AD 22S Block Diagram (both channels identical)

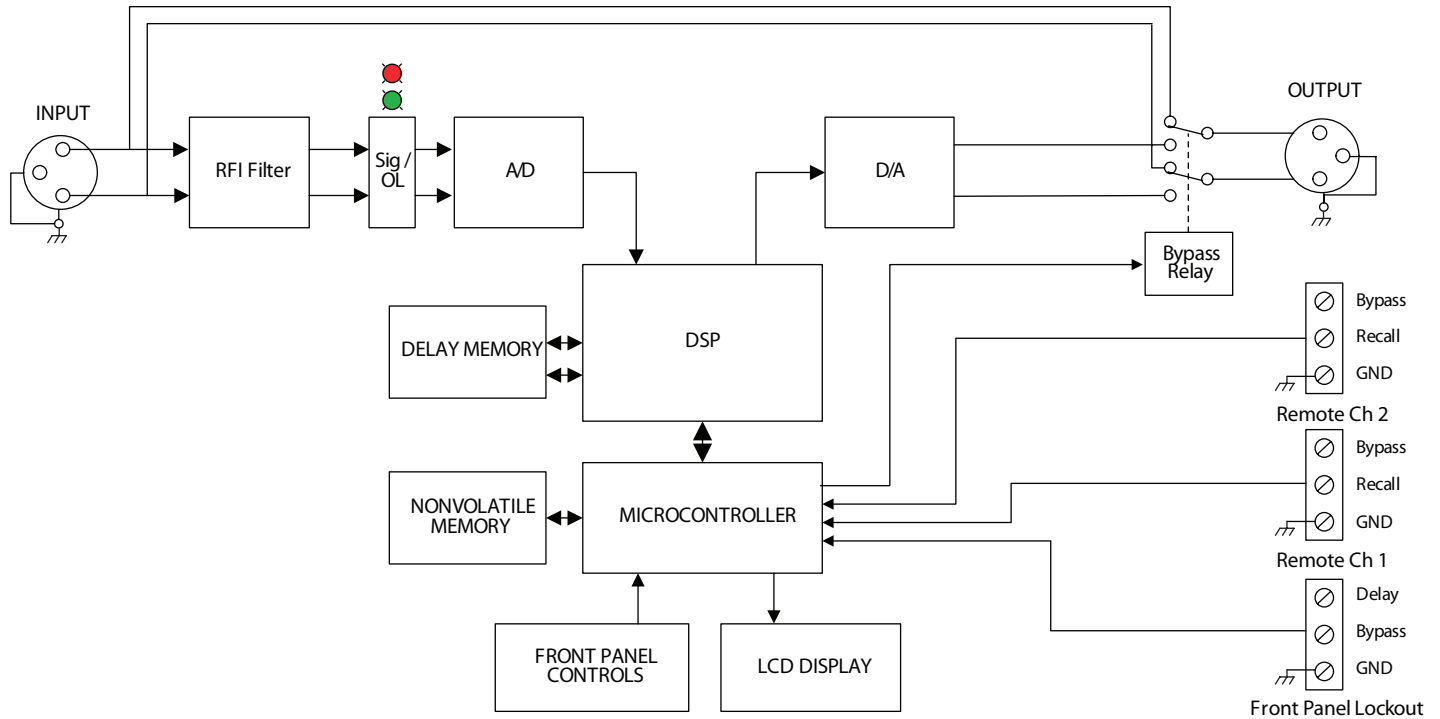

Application Information

DISTANCE MODE

There's more than one way to view your time setting. If you're tired of looking at milliseconds, the delay setting can also be viewed in terms relative to distance by changing the displayed units to feet or meters and by selecting the ambient temperature in either °C or °F. The AD 22S calculates the precise environmental delay by using the relationship of air pressure and temperature to the speed of sound.

VIDEO MODE

The AD 22S is an effective solution to the problem of aligning audio with video in broadcast. Because of the latency involved in processing video streams, timing offset accumulates that can run as high as several frames or lead to noticeable synchronization issues. While in Video mode, the AD 22S displays the delay time in the precise number of frames calculated for your current format and frame rate. You may choose from a selection of the most

common frame rates to match your work situation and environment. As you adjust the number of frames needed to synchronize the audio, the AD 22S calculates the delay to match exactly what you need.

REMOTE RECALL

In some situations it may be necessary to recall a stored setting or enable channel bypass from a location other than where the AD 22S is located. Have a room divider wall? You can install a switch to select between the two room settings automatically when the wall is moved. Does the delay for your outdoor speaker array change with the temperature? Wire up a switch to change from a memory setting adjusted for one temperature to one saved for the other when the weather warms up. For these reasons we have provided remote recall connections on the rear of the unit that can be wired to standard switches installed in any other location.

Rear Panel

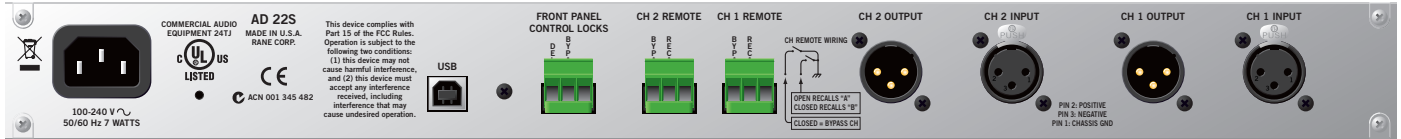

Architectural Specifications

The digital audio delay unit shall be a single rack space, balanced two-input, two-output configuration. The delay adjustment range shall be from 2.00 to 999.99 ms, adjustable in 0.01 ms increments via increment / decrement pushbuttons, in 10 μ s or 1 ms intervals. Additionally, the values shall be selectable in terms of distance in feet or meters, as well as in frames for all common NTSC and PAL / SECAM frame rates.

A 40x2 backlit character LCD shall indicate current delay settings and provide cursor controls for selecting and setting the delay values and configuration parameters, including temperature, frame rate, and stored memory values. Bypass status, signal / overload presence and mode of operation shall be indicated with individual indicators.

Terminals on the rear panel shall allow remote disabling of the front panel controls and bypass switches. Additional terminals shall provide access for remote switches to recall memory settings.

The inputs and outputs shall be active balanced with XLR connectors, and include switchable fail-safe output relays on each channel that automatically enable in the event of power failure. RFI filters shall be provided.

The unit shall be capable of operation by means of its own built-in universal power supply operating at 100-240 VAC and meet CE requirements. The unit shall be UL and cUL listed.

The unit shall be a Rane Corporation AD 22S.

References

1. Shaw, N. "Digital Delays, Parts One, Two & Three," *Sound & Communications*, vol. 39, nos. 3, 5 & 10, (March, May, & October 1993).
2. Bohn, D. "Environmental Effects on the Speed of Sound," *J. Audio Eng. Soc.*, vol. 36, pp. 223-231 (April 1988).