

# OPERATING INSTRUCTIONS

CIRCLE STUDIO MONITORS



FIRST WE LISTEN



INTRODUCTION .....	4
PRECAUTIONS .....	5
SERVICE .....	5
CIRCLE 5 .....	6
Key features (passive and active) .....	6
Key features (active only) .....	6
Active Circle 5 rear panel (fig. 1) .....	7
Passive Circle 5 rear panel (fig. 2) .....	7
CIRCLE 3 .....	8
Key features (passive and active) .....	8
Key features (active only) .....	8
Active Circle 3 rear panel (fig. 3) .....	9
Passive Circle 3 rear panel (fig. 4) .....	9
CIRCLE 1 .....	10
Key features (active) .....	10
Active Circle 1 sub-woofer rear panel (fig. 5) .....	11
LOUDSPEAKER CONNECTION .....	12
Circle 5 and Circle 3 active .....	12
Circle 5 and Circle 3 passive .....	12
Circle 1 active sub-woofer .....	12
5.1 mode - method 1 (fig. 6) .....	13
5.1 mode - method 2 (fig. 7) .....	13
B mode (fig. 8) .....	13
C mode (fig. 9) .....	13
LOUDSPEAKER POSITIONING .....	14
Stereo loudspeaker placement .....	14
Suggested stereo loudspeaker placement (fig. 10) .....	14
Surround loudspeaker placement .....	15
Suggested surround speaker placement (fig. 11) .....	15
TECHNICAL DATA .....	16

# INTRODUCTION

## Circle Studio Monitors

HHB Circle studio monitors are designed and built with HHB's customary attention to detail. More than 20 years' experience and a number of unique innovations have combined to produce studio monitors capable of performing in the most demanding professional environments. The Circle 5 and Circle 3, available in both active and passive versions, together with the Circle 1 sub-woofer, are perfect for use in a variety of stereo and surround sound professional monitoring applications. Extremely responsive, they deliver every performance with power and clarity.

The HHB Circles are a true family in every sense - both in character and appearance. Great consistency in their design and manufacture has resulted in a distinctive Circle sound, uniformly matched across the entire range, enabling Circle 3s and 5s to be freely combined in any surround setup without detrimental effect to the reproduced sound. Striking purple cones or grilles and a durable black paint finish on all models further strengthen the family resemblance.

With their high quality audio components and low distortion filters, the HHB Circle studio monitors are full of features. The cone on the Circle 5 is formed from an injection moulded polymer, with varying thickness across its diameter, for a grain-free texture and minimal cone distortion. And with controls for master volume on the active Circle 3 and 5, along with mode switching, input sensitivity, LF boost and phase controls on the Circle 1, all Circle monitors are fully adaptable for every studio or project installation.

Whether you possess a stereo pair of loudspeakers or an entire surround sound system, the HHB Circle studio monitors are simple to set up and simple to use. With their many flexible options, they offer a tailor-made solution for any monitoring application. These operating instructions for the Circle monitors explain the fundamentals of loudspeaker connection and positioning, providing clear and simple information for monitor installation - whatever your requirements.

# PRECAUTIONS

## Circle Studio Monitors

The active HHB Circle loudspeakers are simple to install, but like all electrical equipment, care must be taken to ensure reliable, safe operation. The following points should always be observed:

- This equipment must be earthed. In a situation using multiple speakers the mains power should be derived from a central set of outlets that have a solid ground connection. Should a problem exist with hum loops, the ground connections on the XLR input connectors should be disconnected, not the mains earth connection. The mains earth connection must NEVER be removed from these speakers.
- Ensure the speakers are the correct voltage for the available mains supply.
- All mains wiring should be installed and checked by a qualified electrician.
- To prevent fire or electric shock hazard do not operate this equipment outside, or expose to rain or moisture. Do not operate when disassembled or if the cabinet is damaged, exposing the internal electronics.

- When replacing the fuse in the active Circle 5, Circle 3 and Circle 1, use only the correct rating of fuse - a 2A slow blow type for the Circle 5A and Circle 1A, or a 630mA slow blow type for the Circle 3A. The fuses used must conform to local safety regulations.
- As the performance of a new loudspeaker will improve after the first few hours of use due to the bedding in of the cone materials and suspensions, it is recommended that new speakers should be driven at a moderate level for a few hours before critical listening is attempted.

**BEWARE** - HHB Circle studio monitors are capable of producing high sound pressure levels. Be careful not to monitor at high volumes for long periods as this could cause hearing damage.

# SERVICE

## Circle Studio Monitors

Should a HHB Circle monitor require service, it must be taken or sent to an HHB authorised dealer. Please retain the original packing for possible future use, and ensure the unit is suitably protected during transit. The manufacturer cannot accept responsibility for damage caused during transportation. In order to register ownership it is essential that you complete and return the user registration card supplied with this product. All

components used in HHB Circle studio monitors are guaranteed against faulty materials or workmanship for a period of one year from the date of purchase. This warranty will become void if the product has been misused, modified or tampered with in any way. HHB shall not be liable for any consequential or incidental damages due to the failure of this product. In the unlikely event of a product failure please contact your local dealer.

Please record the following details:

Serial number: .....

Date purchased: .....

Dealer: .....

As part of a complete monitoring system, HHB Circle 5 studio monitors will deliver the clean, highly accurate sound required. Their reliable sound output and wide flat frequency response makes them suitable for the highest quality audio monitoring applications. The Circle 5s feature a solid state Polyswitch® to protect the tweeter from excessive input. Unlike other protection circuits which limit power to the tweeter, affecting the overall balance of the sound in a way which may not be immediately obvious to the listener, the Polyswitch® in the Circle 5 cuts all power to the tweeter and illuminates a red warning LED. After a couple of minutes to cool off, the switch automatically resets, having saved the tweeter from overload and subsequent damage.

## CIRCLE 5 KEY FEATURES

### Active & Passive

- Detailed, accurate and dynamic sound, both on and off axis
- Tight, controlled low-end performance
- Accurate bass / treble driver time alignment
- 200mm (8") bass/mid driver with a unique, injection moulded cone for increased dynamics and minimal bass colouration
- Individually tested ferro-fluid cooled soft dome tweeter
- Solid state, Polyswitch® tweeter overload protection
- Shielding antimagnets allow use close to video and computer monitors
- Rigid, seamless ported cabinet, finished in durable black paint

### Active Only

- 120W LF / 70W HF integral amplifier pack
- Switchable inputs; either balanced XLR or unbalanced RCA phono
- Push-Pull amplifier design for tight, controlled low-end performance
- Power amplifier contains anti-thump on / off circuitry
- Extra-large toroidal transformer for added headroom and low hum field
- Individually calibrated, low Q Sallen and Key active filters eliminate mid-band peaks, resulting in a sound that doesn't tire the listener, even after long periods
- Long life smoothing capacitors
- Massive heat sink for effective heat dissipation



## Active Circle 5 Rear Panel

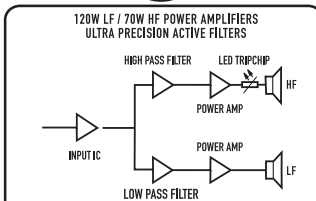
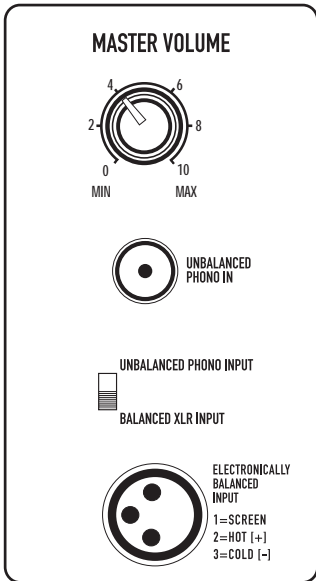

	<p><b>CAUTION</b> Risk of electric shock! DO NOT OPEN</p> <p><b>ATTENTION</b> Risque de choc électrique! NE PAS OUVRI</p>	
<p><b>ACHTUNG</b> Vor dem Öffnen des Gerätes Netzstecker ziehen!</p>		

HHB COMMUNICATIONS • MANUFACTURED IN THE UK  
LONDON • LOS ANGELES • TORONTO

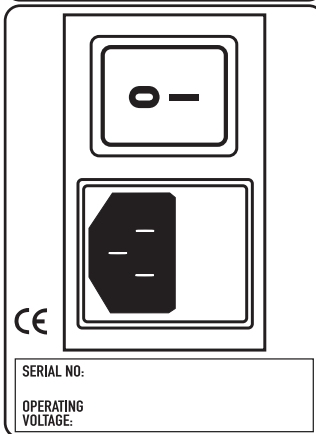

THIS EQUIPMENT MUST BE EARTHED  
NO USER SERVICEABLE PARTS  
INDOOR USE ONLY



## Passive Circle 5 Rear Panel

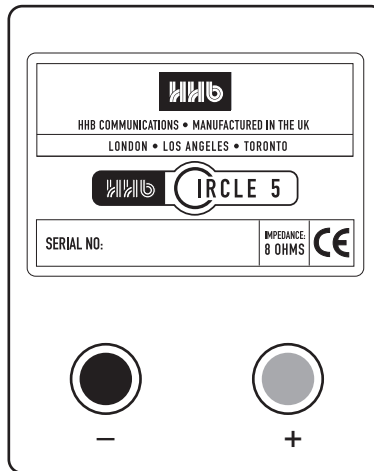

The compact size of the HHB Circle 3 studio monitor is ideal when space is at a premium. Equally at home in project or commercial studios, the Circle 3 features a 4.5" paper pulp cone, optimised for use in the smaller cabinet. An anti magnet screen allows the Circle 3 to be placed next to computer or video monitors. The Circle 3 monitors can be used as part of a surround sound system since, passive or active, they produce a sound which is both clear and dynamic – the HHB house sound.

### CIRCLE 3 KEY FEATURES

#### Active & Passive

- High quality sound reproduction in a compact package
- Ideal for smaller mixing applications
- Acoustically dead chassis
- Accurate bass / treble driver time alignment
- 110mm (4.5") non-resonant suspension coupling bass/mid driver with a paper pulp cone optimised for smooth, accurate sound reproduction with minimum distortion
- Individually tested ferro-fluid cooled soft dome tweeter
- Magnetically screened for use close to video / computer monitors
- Rigid, seamless cabinet, finished in durable black paint

#### Active Only

- 60W LF / 60W HF integral amplifier pack
- Switchable inputs; either balanced XLR or unbalanced RCA phono
- Power amplifier contains anti-thump on/off circuitry
- Anti-resonant amplifier mounting
- Low noise audio integrated circuits
- Advanced surface mount computer assembled PCB construction
- Toroidal transformer for added headroom and low hum field
- Individually calibrated Sallen and Key active filters
- Controlled crossover characteristics to eliminate listening fatigue during long recording or mixing sessions



**Figure 3**

**Active Circle 3  
Rear Panel**

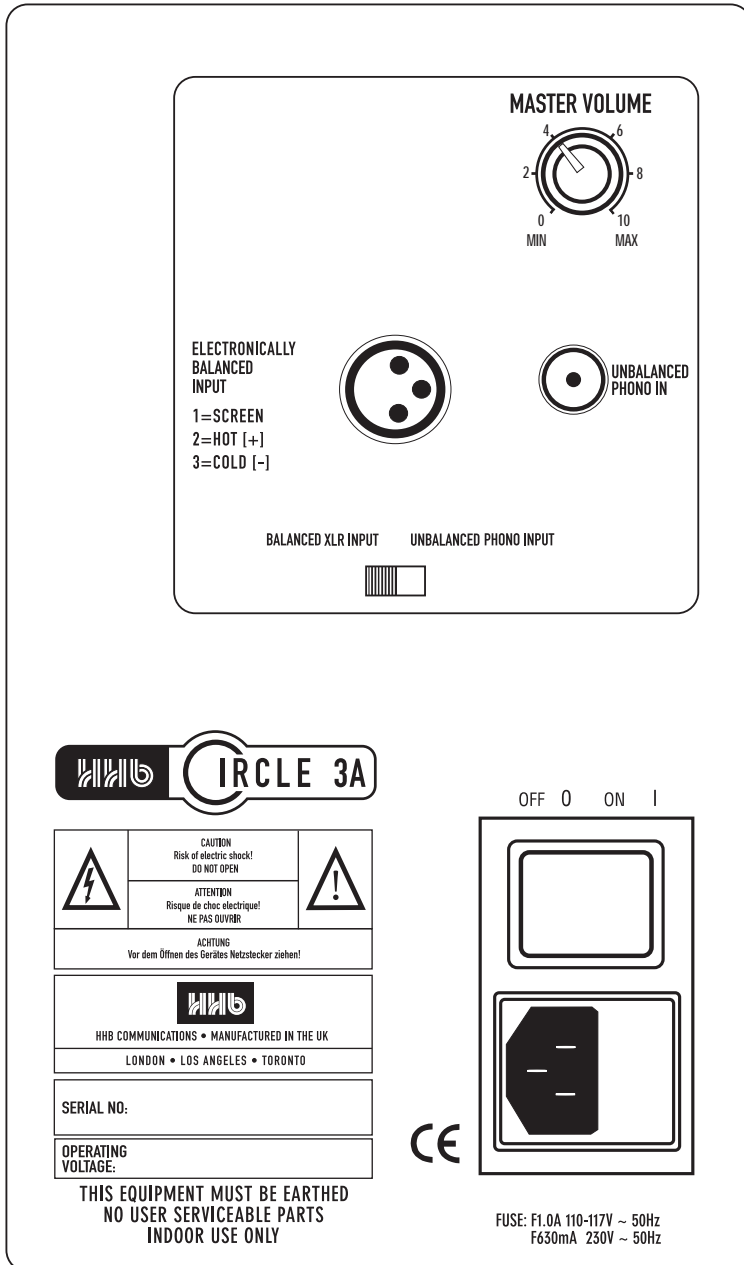

**Figure 4**

**Passive Circle 3  
Rear Panel**

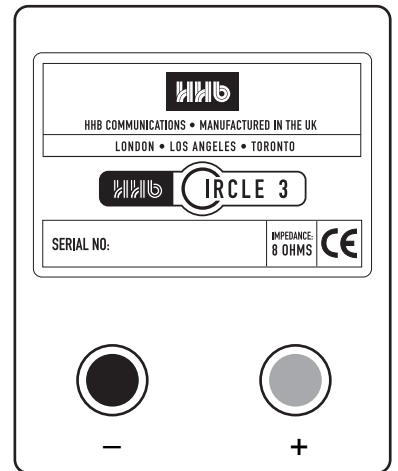

The Circle 1 active sub-woofer is the perfect loudspeaker to complement the Circle 5 and Circle 3 in surround sound applications. Faithfully reproducing all the low frequency effects found in films and music, the HHB Circle 1 greatly improves the bandwidth of loudspeaker systems. With its built-in active crossover, any combination of up to five full-range loudspeakers, depending on the application, may be connected to the Circle 1, allowing its on-board filters to remove extreme low frequency content from the other signals, preventing their overload whilst attempting to reproduce these high energy frequencies. With this arrangement, no additional filtering is needed. Dedicated sub-woofer signals may be sent directly from a mixing console or multitrack recorder to the Circle 1 (5.1 mode), or the internal circuitry can extract the low frequency information from the left, centre and right input signals (B mode). In C mode, low frequency information is filtered from the left, centre and right input signals and added to the sub-woofer signal, ensuring optimum low frequency performance. The Circle 1's paper pulp 12" LF driver is mounted at the top of the cabinet, displacing air out of the acoustically optimised front port.

### CIRCLE 1 KEY FEATURES

- Designed for use as an integral part of any surround sound monitoring system
- Increases the bandwidth of a loudspeaker system down to 33Hz
- Exceptionally low colouration and distortion
- 300mm (12") paper pulp bass/mid driver
- Low moving mass for fine transient response characteristics
- Air-cooled magnet system
- Very large voice coil and long throw suspension
- Flexible configuration possibilities, with direct input of sub-woofer signal (5.1 mode) or low frequency information extracted from the left, centre and right signal paths and fed internally (B mode) or summed (C mode) to the sub-woofer input within the Circle 1
- Balanced XLR and unbalanced RCA phono sub-woofer input
- Built-in 5-channel Sallen and Key active filters remove the need for external filtering
- Low noise, low distortion power supply with long life smoothing capacitors
- Variable phase control allows blending with existing speaker / room combinations
- Variable bass boost control achieves optimum bass balance across a range of differing listening levels (lower listening levels require bass boost according to psychoacoustic theory)
- Input sensitivity control allows matching of sound balance across the whole surround monitor system
- Built-in temperature overload sensor
- Rigid, ported cabinet, finished in durable black paint
- Distinctive purple grille



Figure

# Active Circle 1 Sub-Woofer Rear Panel



	CAUTION Risk of electric shock! DO NOT OPEN	
	ATTENTION Risque de choc électrique! NE PAS OUVRI	
ACHTUNG Vor dem Öffnen des Gerätes Netzstecker ziehen!		
HHB COMMUNICATIONS • MANUFACTURED IN THE UK LONDON • LOS ANGELES • TORONTO		
SERIAL NO:		CE
OPERATING VOLTAGE:		

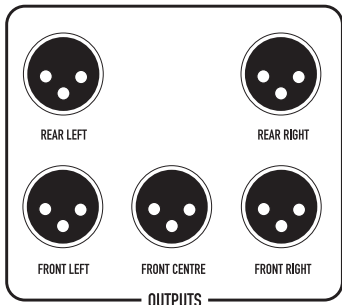
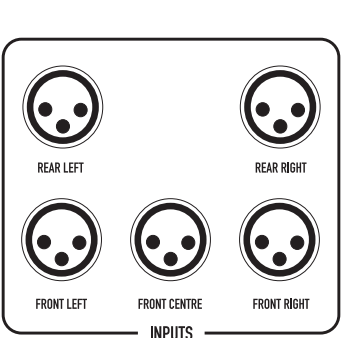
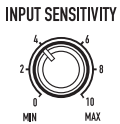

THIS EQUIPMENT MUST BE EARTHED  
NO USER SERVICEABLE PARTS  
INDOOR USE ONLY

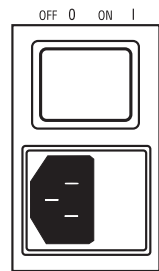

# LOUDSPEAKER CONNECTION

Circle Studio Monitors

## Circle 5 & Circle 3 - Passive

Choosing an amplifier to match your speakers and application is important. The passive HHB Circle 5 requires connection to a power amplifier with a suggested output between 50 and 200 Watts RMS, and the Circle 3 should be powered by an amplifier with an output of 30 to 100 Watts. Connection is made via a pair of binding posts on the rear of the loudspeaker. Take care to ensure that the positive (red +) terminal on the loudspeaker is connected to the positive (red +) terminal on the amplifier, and that the negative (black -) terminal on the speaker is connected to the negative (black -) terminal on the amplifier. Connecting one of the loudspeakers out of phase will result in dramatic loss of low frequency signals and an incoherent spatial image. Always use good quality medium or heavy-duty speaker cable, not thin 'bell' wire. The main function of a speaker cable is to transfer the maximum amount of current with the minimum amount of distortion. It is therefore preferable to have a cable with a wide cross-sectional area, since this will reduce the electrical resistance. If the cable is too thin, the resistance rises and heating may occur. Where possible, try to use the same length of cable for each speaker.

## Circle 5 & Circle 3 – Active

Audio connection to the active HHB Circle 5 and Circle 3 is via balanced XLR or unbalanced RCA phono. A switch selects the desired audio input. The active Circle 5 and 3 should be connected to a suitable mains power supply via an IEC connector. Power should be switched off when connecting or disconnecting any signal to or from the loudspeakers, or when changing the position of the selector switch, since the loudspeakers and internal amplifiers may be damaged. When audio cable runs are long – about ten metres or more (approximately thirty feet) – or there is electromagnetic interference in the vicinity of the cable (from a motor, for instance), it is advisable to use balanced XLR cables so as to avoid any induced noise. The master volume control on the active Circle 5 and 3 acts as a sensitivity control. When at its highest, the input is at maximum sensitivity and the amplifiers will be fully driven by an input of 1V. The best way to set this correctly is to ensure that the monitor output of the mixing desk or other equipment that is driving the speakers, is set to produce a peak output of 1V. The master volume control also allows for balancing between loudspeakers; ideal for use in a surround sound environment.

## Circle 1 Active Sub-Woofer

The HHB Circle 1 is an active sub-woofer, containing built-in amplification and active crossover circuitry, designed especially for use with Circle 5 and Circle 3 loudspeakers in a surround sound setup. Its flexible input and output capabilities allow quick and simple connection to the other loudspeakers. The HHB Circle 1 sub-woofer has three distinct modes of operation, set by a switch on the rear panel – these modes are '5.1', 'B' and 'C'. The system is designed for decoded or discrete 5.1 reproduction but also caters for earlier formats of surround sound or bass enhancement in a conventional stereo system. Using the HHB Circle 1 in '5.1 mode' there are two connection methods in a surround sound system. With method 1, the separate sub input allows direct connection from a dedicated line level low frequency effects (or sub) channel on a surround sound decoder, mixing desk, or a multitrack recorder. Using this method, only one physical connection is made to the sub-woofer – the other five loudspeakers are sent their own discrete signals directly from the mixing desk, etc.

Figure 6

### 5.1 mode - method 1

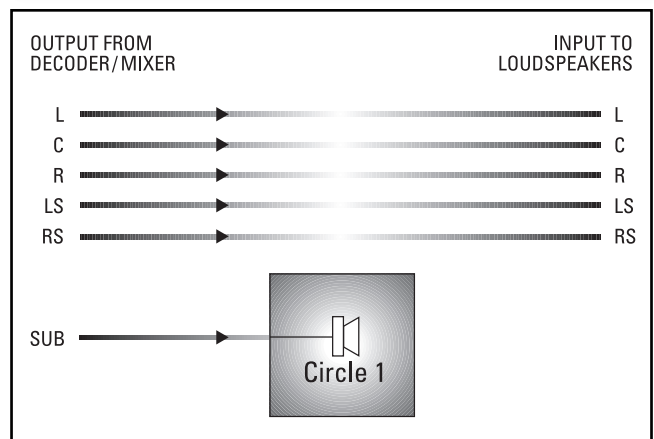

In the second connection, method 2, all the monitor signal outputs (normally left, centre, right, left surround and right surround) are connected to the inputs on the HHB Circle 1, and the outputs are fed to the loudspeakers. This method filters the low frequencies (below 120Hz) from the loudspeaker feeds. The sub-woofer is always driven from the SUB input – it receives no low frequency information from the other five inputs. This connection method is widely used, since by removing the extreme low frequencies, the five

full-range loudspeakers can be utilized more efficiently. This method of signal connection makes the most of the Circle 1's high quality filters.

Figure 7

### 5.1 mode - method 2

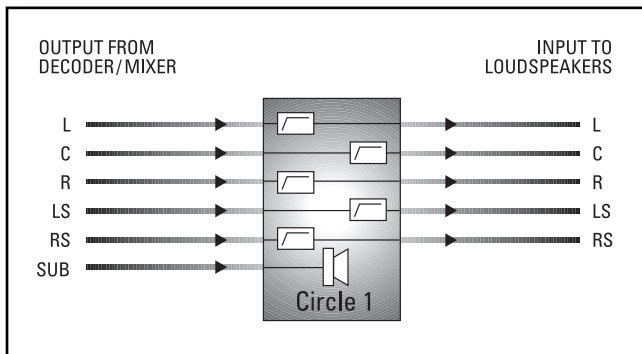

Using the HHB Circle 1 in 'B mode', the bass frequencies are extracted from the left, centre and right inputs and not from the SUB input. The left and right monitor signals (or left, centre and right) are connected to the XLR inputs and the bass (below 120 Hz) is filtered from these signals, equally mixed together and fed to the sub-woofer. The rest of the frequency spectrum from these inputs is output from the left and right (or left, centre and right) XLRs as normal for connection to Circle 3 or Circle 5 speakers. This mode allows optimum flexibility with both stereo and LCR source formats.

Figure 8

### B mode

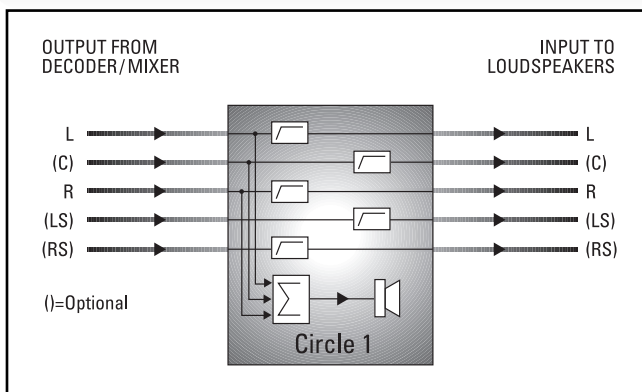

With the HHB Circle 1 in 'C mode', the bass frequencies are filtered from the left, centre and right inputs and summed together with the signal from the SUB input (either XLR or RCA phono). This method of connection ensures that any dedicated sub bass mix is always reproduced by the Circle 1.

Figure 9

### C mode

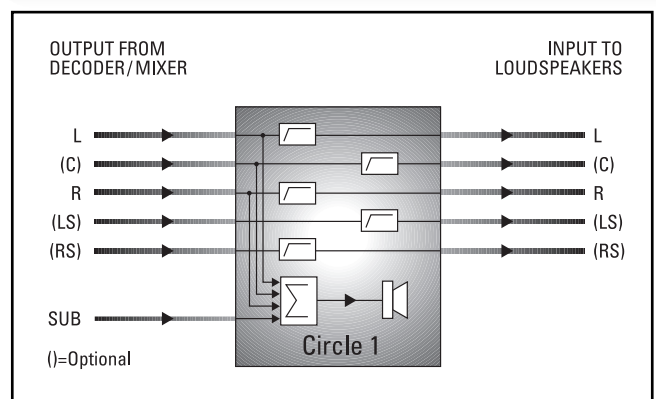

The three controls on the HHB Circle 1 allow simple configuration for each particular surround setup. An input sensitivity level adjusts the volume of the sub woofer, without affecting any of the other signals that may be passing through the filter stages of the unit. The bass boost control provides approximately 10dB of boost in a half octave centred at 33Hz. The function of this is to compensate for the frequency response of the human ear when listening at low levels. The boost control should normally be set near minimum when listening at mid to high levels, but the boost level may be increased as the listening level is reduced. Please note that the HHB Circle 1 is not designed to be used at full boost and very high level. Some user adjustment is required to obtain the optimum balance between the preferred sound and power handling / power capacity of the system. The phase control is provided to enable smooth integration of the Circle 1 with other loudspeakers in the surround system; this control alters the phase of the sub-woofer signal through 180°, enabling the sub-woofer to blend with the other loudspeakers in the system, whatever your monitoring requirements. The phase control should be adjusted to obtain the best, smoothest balance between the deep, mid and upper bass along with the mid and high frequencies in the Circle surround system, with the entire system installed and in the correct positions.

# LOUDSPEAKER POSITIONING

## Circle Studio Monitors

Whether you have a stereo or surround sound system, correct positioning of loudspeakers in the room is essential, as this will greatly affect the accuracy of the reproduced sound. Speakers radiate sound from all directions and therefore placing them against walls or on the floor is not advisable. HHB Circle 5 and Circle 3 monitors are optimised for use under free-field conditions - so for the best results, consider the following points when setting up your loudspeaker system.

### STEREO LOUDSPEAKER PLACEMENT

- The Circle 5 and Circle 3 loudspeakers should be placed upright on stands, away from boundaries to reduce reflections. Do not place them on their sides, as the response at the crossover frequency will be less accurate.
- Both speakers should be the same distance from the listening position.
- The Circle 5 and Circle 3 loudspeakers should be slightly angled in towards each other, so as to point towards the listening position, and placed at a height where the listener's ears are level with the tweeters.
- Ideally, the two loudspeakers and the listener should sit at the corners of a triangle, where all sides are of equal length:
- The listener should not sit too close to the speakers, (i.e., within this imaginary triangle), since the important centre image (sweet spot) can be greatly affected when listening in this position.
- The loudspeakers should be placed away from corners and walls - more than one metre away (approximately three feet) is ideal - since there may be unwanted interference patterns caused by the reflections of the signal from the walls, which will colour the low and mid frequencies, giving the impression of extreme bass warmth and unnatural midrange.
- At these low frequencies, the sound from the loudspeakers radiates in all directions, and reflects off any hard surfaces to combine with the direct sound. At higher frequencies, sound from the loudspeakers is more directional, causing less of a problem with interference.
- Avoid placing the Circle 5 or Circle 3 studio monitors on top of a mixing console, since this will adversely affect the frequency response. Some of the sound output will reflect off the surface of the console, interfering with the direct sound from the loudspeakers. Instead, position the speakers on stands slightly behind and above the console.

### 10 Figure

#### Suggested stereo loudspeaker placement

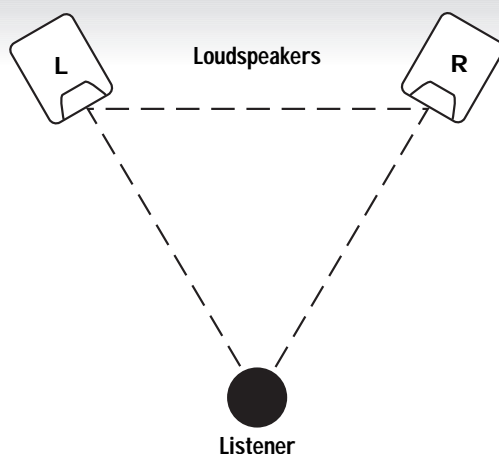

## SURROUND LOUDSPEAKER PLACEMENT

- The loudspeaker arrangement for surround sound monitoring may comprise three front channels and two surround channels, each placed upright on stands an equal distance from the listening position.
- A sub-woofer is often used to improve the system's low frequency response. A typical setup may consist of five HHB Circle 5 loudspeakers with a Circle 1 sub-woofer.
- Ensure that all five loudspeakers are positioned at the same height - ideally, this will be so that the tweeters are level with the listener's ears.
- Due to the consistent sound quality of the HHB Circles, it is possible to mix Circle 5s and Circle 3s in the same surround setup. The front three speakers, left, centre and right, may be Circle 5s, with a pair of Circle 3s used for left surround and right surround.
- Widely used in films and pop music, extreme low frequency effects, as produced by the HHB Circle 1, are often felt rather than actually heard.
- Since the Circle 1 sub-woofer will only produce low frequencies, often with a wavelength of up to ten metres, it is often hard to localise, enabling the speaker to be placed on the floor or slightly to one side of the listening position without altering the overall spatial image.
- Distance from the listening position to each of the loudspeakers should always be the same. If the listener is at the centre point of an imaginary circle, the speakers should all lie on the circle's circumference.
- There are no hard and fast rules as to the exact placing of the left and right surround loudspeakers - this circular diagram is merely intended as a guide. In fact, many recording and mixing studios have their surround loudspeakers mounted on moveable trolleys, enabling each client to place them in their preferred position.

Figure 11

Suggested surround loudspeaker placement

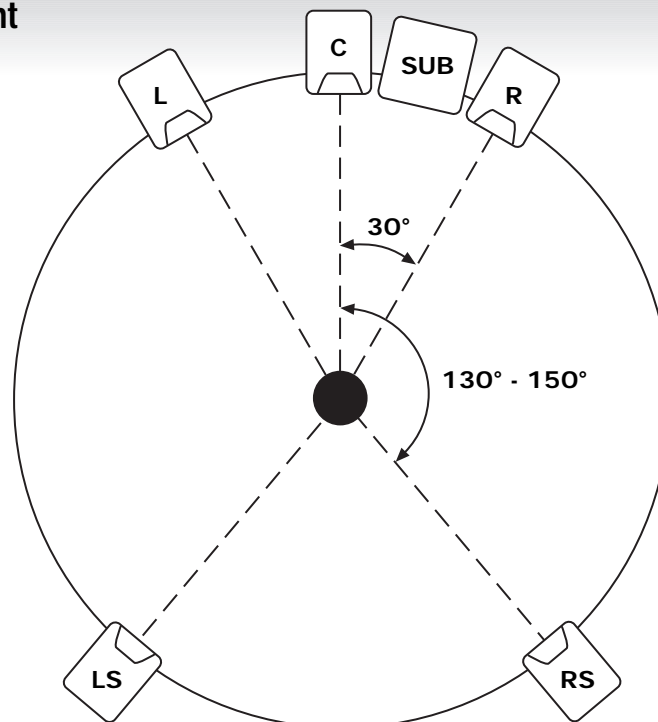

# TECHNICAL DATA

## Circle Studio Monitors



### Circle 3 Passive

Transducer System ..... 2 way monitor loudspeaker.  
Drive Units ..... LF: Custom 110mm (4.5") NRSC cone,  
25mm (1") voice coil, high linearity low-loss suspension  
rigid self-sealing polymer chassis and shielding antimagnet.  
HF: 25mm (1") ferro-fluid cooled soft dome, high efficiency Neodymium magnet,  
highly focused magnetic field 25mm (1") aluminium voice coil.  
Frequency Response ..... 70Hz - 20kHz +/-3dB.  
Sensitivity ..... 83dB 1W/1m.  
Suggested Amplifier Power ..... 30 - 100W.  
Impedance ..... 8 Ohms nominal.  
Power Handling (Programme) ..... 60W.  
Crossover ..... Pro-grade components on fibreglass PCB,  
critically damped, 3.5kHz crossover.  
Connectors ..... Binding posts.  
Dimensions (HxWxD) ..... 270mm x 175mm x 197mm / 10.6" x 6.9" x 7.8".  
Weight ..... 3.7kg (8.1lbs) each (net), 8.4kg (18.5lbs) packed in pairs (gross).  
Finish ..... Durable black paint finish.

### Circle 3 Active

As passive, but with the addition of an internal power amplifier.

Sensitivity For Full Output with Input sensitivity control at max: ..... 1V RMS.  
Power (Programme) ..... 60W Bass, 30W Tweeter.  
Active Crossover ..... Crossover point at 3.5kHz.  
Sallen & Key active filters for LF and HF.  
Advanced design using ultra high precision components.  
Low noise audio semiconductors and 1% precision  
resistors throughout audio circuitry.  
Power Amplifier ..... Anti thump on/off circuitry.  
Regulated low noise and distortion power supply.  
Connectors ..... Slide Switchable XLR (female) or RCA phono.  
Main Input Voltage ..... European model: 220-240V, 50Hz.  
U.S. / Canadian model: 110-120V, 60Hz.  
Dimensions (HxWxD) ..... 270mm x 175mm x 220mm / 10.6" x 6.9" x 8.7".  
Weight ..... 5.0kg (11.0lbs) each (net), 11.0kg (24.2lbs) packed in pairs (gross).  
Both active and passive Circle 3s are packaged in pairs. Single units can also be ordered.



### Circle 5 Passive

Transducer System ..... Ported 2 way monitor loudspeaker.  
Drive Units ..... LF: Custom 200mm (8") polymer cone,  
high compliance long throw rubber surround.  
25mm (1") high temperature aluminium voice coil and antimagnet.  
HF: Custom 28mm (1.1") ferro-fluid cooled soft dome  
with rear damping chamber. 28mm (1.1") high temperature  
aluminium voice coil and antimagnet.  
Frequency Response ..... 48Hz - 20kHz, +/- 3dB.  
Sensitivity ..... 87dB 1W/1m.  
Suggested Amplifier Power ..... 50 - 200W.  
Impedance ..... 8 Ohms nominal.  
Power Handling (Programme) ..... 120W.  
Crossover ..... Pro-grade components on fibreglass PCB,  
critically damped, 2.6kHz crossover.  
Connectors ..... Binding posts.  
Dimensions (HxWxD) ..... 420mm x 255mm x 300mm / 16.5" x 10.0" x 11.8".  
Weight ..... 10.0kg (22.0lbs) each (net), 20.4kg (44.9lbs) packed in pairs (gross).  
Finish ..... Durable black paint finish.

### Circle 5 Active

As passive, but with the addition of an internal power amplifier.

Sensitivity For Full Output ..... 1V RMS.  
Power (Programme) ..... 140W Bass, 70W Tweeter.  
Active Crossover ..... Crossover point at 2.6kHz. Sallen & Key active filters for LF  
and HF. Advanced design using ultra high precision components.  
Low noise audio ICs and 1% precision resistors used throughout.  
Power Amplifier ..... LF unit driven by twin power ICs in Push-Pull mode.  
HF unit driven by a single IC. Anti thump on/off circuitry.  
Regulated low noise, low distortion power supply with long life  
capacitors, guaranteeing full power over a long service life.  
Polyswitch® tweeter overload protection with LED indicator.  
Every module calibrated against reference for perfect stereo imaging.  
Connectors ..... Switchable XLR / RCA phono.  
Main Input Voltage ..... European model: 220-240V, 50Hz.  
U.S. / Canadian model: 110-120V, 60Hz.  
Dimensions (HxWxD) ..... 420mm x 255mm x 300mm / 16.5" x 10.0" x 11.8".  
Weight ..... 12.6kg (27.7lbs) each (net), 25.6kg (56.3lbs) packed in pairs (gross).  
Both active and passive Circle 5s are packaged in pairs. Single units can also be ordered.



### Circle 1 Powered Sub-Woofers

Transducer System ..... Active bandpass twin chamber reflex sub-woofer.  
Drive Units ..... LF: 300mm (12") double-magnet, contour-optimised cone with  
high compliance long throw rubber surround rigid magnesium chassis.  
Low moving mass for fast transient attack. Air-cooled magnet system. 40mm (1.6") diameter aluminium voice coil.  
Frequency Response ..... 33Hz - 120Hz, +/- 3dB in free space.  
Sensitivity For Full Output, input sensitivity at max, sub woofer (effects) channel ..... 1V RMS.  
Controls ..... Input sensitivity, LF boost, phase.  
Active Crossover ..... 5 main channels pass through Sallen & Key filters, crossover point at 120Hz, and  
are available in XLR outputs. Advanced design using ultra high precision components.  
Low noise audio semiconductors and 1% precision resistors used throughout audio circuitry.  
Power Amplifier ..... 160W min (programme). Anti thump on/off circuitry. Regulated low noise, low distortion power supply with long life capacitors,  
guaranteeing full power over a long service life.  
Connectors ..... XLR inputs (female): L, C, R, L rear, R rear. XLR (female): Sub-woofer (effects channel)  
XLR outputs (male) L, C, R, L rear, R rear,  
all band limited to 120Hz to connect to 'satellite' speakers.  
Main Input Voltage ..... European model: 220-240V, 50Hz. U.S. / Canadian model: 110-120V, 60Hz.  
Dimensions (HxWxD) ..... 465mm x 414mm x 414mm / 18.3" x 16.3" x 16.3".  
Weight ..... 21.5kg (47.3lbs) each (net), 27.0kg (59.4lbs) packed in singles (gross).  
Finish ..... Durable black paint finish with perforated purple grille.

Dealer Stamp



**FIRST WE LISTEN**

[www.hhb.co.uk](http://www.hhb.co.uk)

**HHB Communications Ltd** · 73-75 Scrubs Lane, London NW10 6QU, UK  
Tel: 020 8962 5000 · Fax: 020 8962 5050 · E-Mail: [sales@hhb.co.uk](mailto:sales@hhb.co.uk)

**HHB Communications USA LLC** · 1410 Centinela Avenue, Los Angeles, CA 90025-2501, USA  
Tel: 310 319 1111 · Fax: 310 319 1311 · E-Mail: [sales@hhbusa.com](mailto:sales@hhbusa.com)

**HHB Communications Canada Ltd** · 260 King Street East, Toronto, Ontario M5A 4L5, Canada  
Tel: 416 867 9000 · Fax: 416 867 1080 · E-Mail: [sales@hhbcanada.com](mailto:sales@hhbcanada.com)